

FLUID COOLING | Mobile M Series

AIR COOLED M

Features

- High Strength Construction
- 3/8" Tube Size
- Eliminate Piping, Reduce Cost with Optional Built-in Relief Bypass
- Aluminum Fins
- Rugged Steel Manifolds
- Heat Removal up to 90,000 BTU/Hr.
- Oil Flows to 100 GPM
- Mounting Brackets Included
- SAE, NPT or 37° Flair Oil Connections

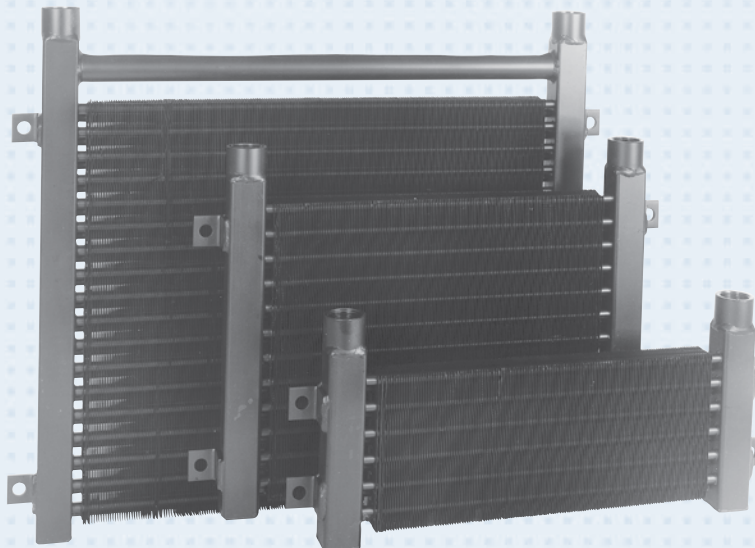

Ratings

Operating Pressure 300 psi
Test Pressure 300 psi
Operating Temperature 400° F

Materials

Tubes Copper
Fins Aluminum
Turbulators Steel
Manifolds Steel
Relief Valve Steel
Connections Steel

How to Order

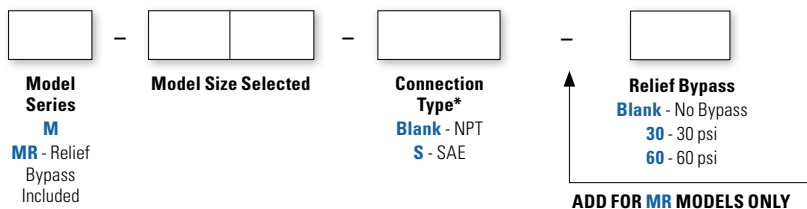

*Other connection types available. Please consult factory for assistance.

Dimensions & Weights

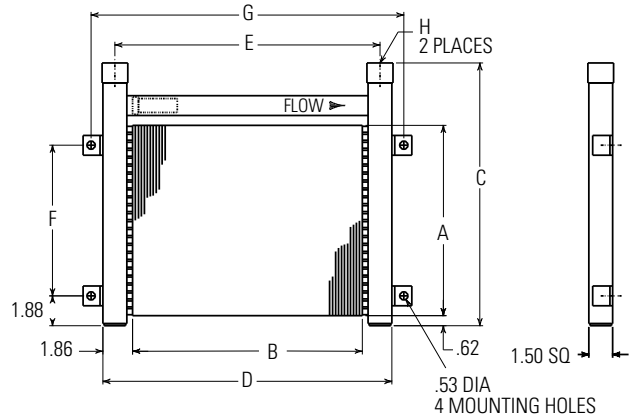
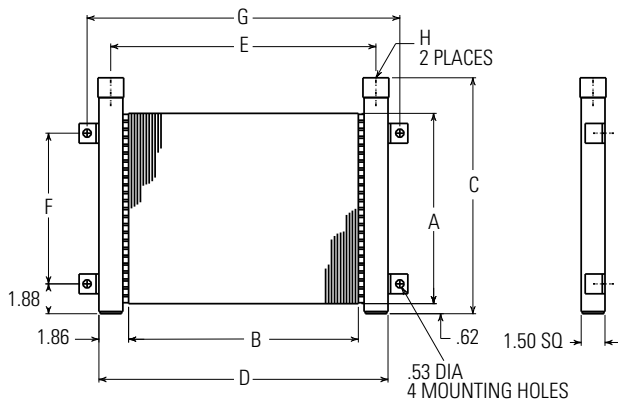

Unit shown with optional Bypass Valve

Model	A	B	C		D	E	F	G	H		Face Area (Sq. Ft.)	Shipping Weight Lbs.
			M Series	MR Series					NPT	SAE		
M-10	6.00	14.50	8.88	10.56	18.22	16.72	3.50	19.72	1.00	#16	.60	11
M-15	8.00		10.88	12.56			5.50				.81	12
M-20	12.00		14.88	16.56			9.50				1.21	16
M-25	18.00	20.50	20.88	22.56	24.22	22.72	15.50	25.72	1.25	#20	2.56	28
M-30	24.00	19.50	26.88	28.62	23.22	21.72	21.50	24.72			3.25	34
M-35	30.00		32.88	34.62			27.50				4.06	40
M-40	36.00	25.00	38.62	40.69	28.72	27.22	33.50	30.22	1.25	#20	6.25	56
M-45		35.50			39.22	37.72		40.72			8.88	73

Performance Curves

AIR COOLED M

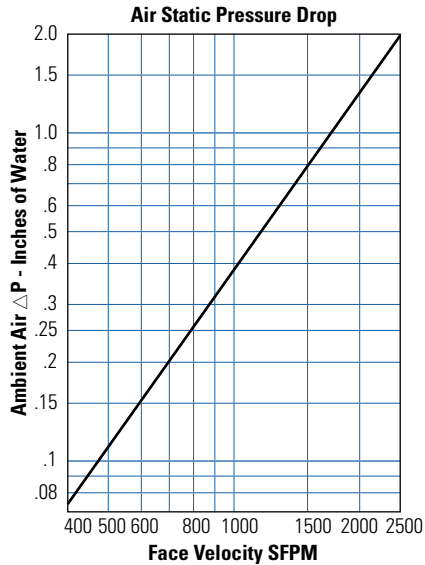
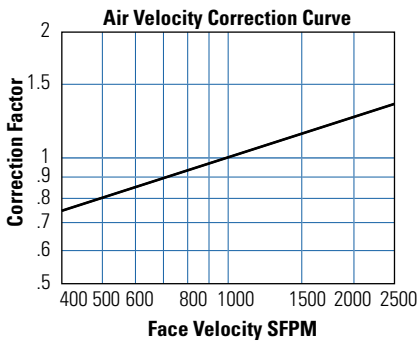
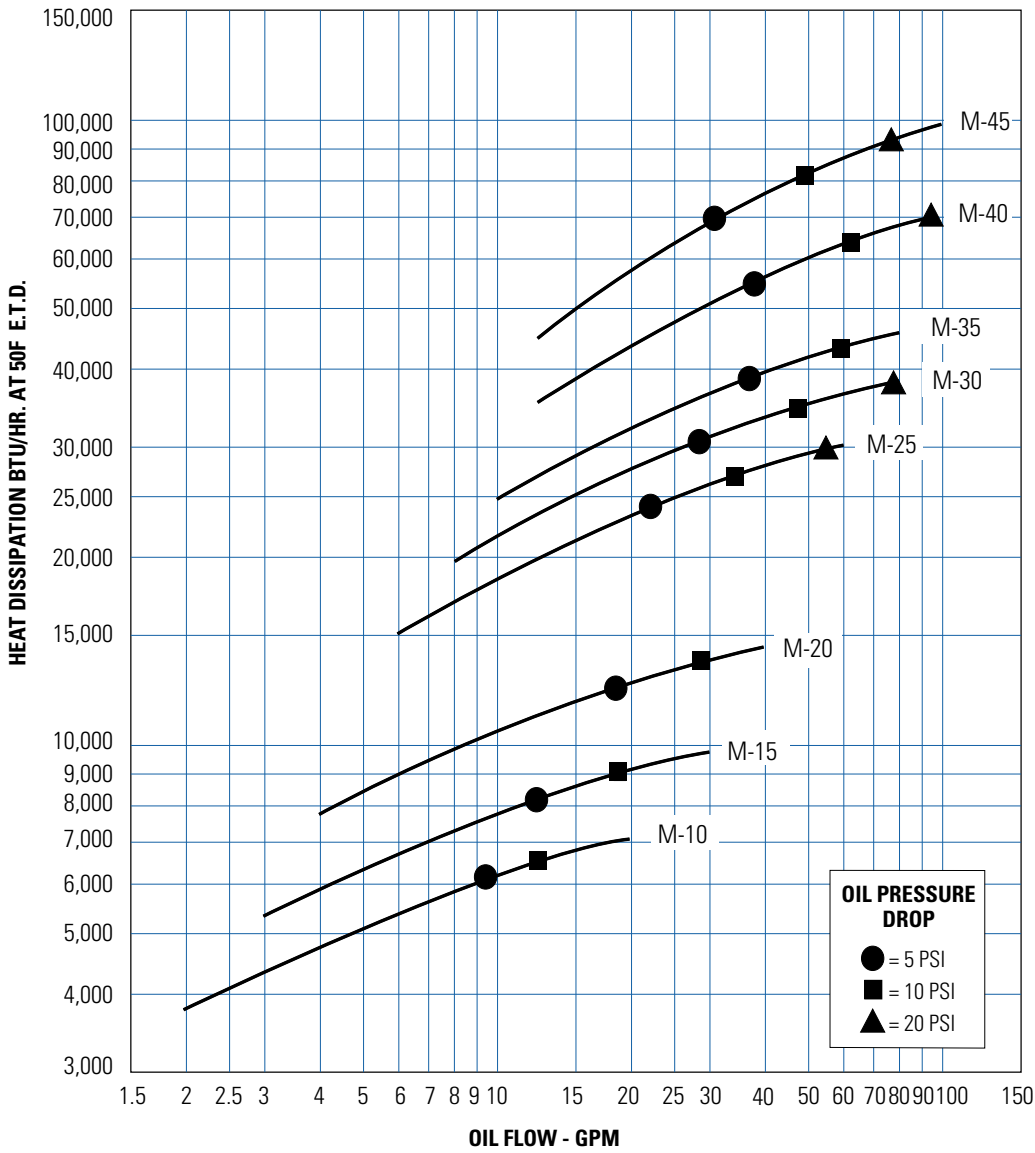

Selection Procedure

Performance Curves are based on 50 SSU oil, 1000 Standard Feet per Minute (SFPM) Air Velocity, and a 50°F Entering Temperature Difference (E.T.D.) E.T.D. = Entering oil temperature - Ambient air temperature

Step 1 Determine Heat Load: Heat load may be expressed as either Horsepower or BTU/Hr. To convert Horsepower to BTU/Hr: BTU/Hr. = Horsepower x 2545

Step 2 Calculate entering temperature difference: The entering oil temperature is generally the maximum desired oil temperature. E.T.D. = Entering oil temperature - Ambient air temperature

Step 3 Determine Air Velocity Correction Factor:
 A. If SFPM (Standard Feet per Minute) air velocity is known, read value from curve above. A reasonable assumption for this value is 750 SFPM.
 B. If SCFM (Standard Cubic Feet per Minute) air flow is known, calculate velocity as follows:

$$\text{SFPM Air Velocity} = \frac{\text{SCFM Air Flow}}{\text{Ft}^2 \text{ Face Area of Cooler}}$$

Step 4 Calculate corrected heat load to enter curves:

$$\text{Corrected Heat Dissipation} = \frac{\text{BTU/Hr. (Heat Load)}}{\text{Desired E.T.D.}} \times \frac{50^\circ\text{F} \times \text{Cv}}{\text{Air Velocity Correction Factor}}$$

Step 5 Enter the Performance Curves at the bottom with the GPM oil flow and proceed upward to the adjusted heat load from Step 4. Any curve on or above this point will meet these conditions.

Step 6 Multiply oil Pressure Drop from curve by correction factor found in Oil Δ P Correction Curve.

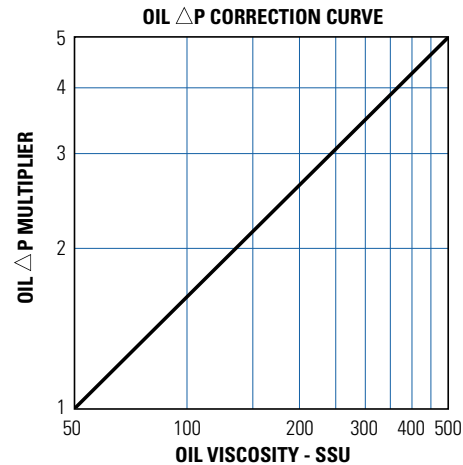

C_v Viscosity Correction

Average Oil Temp °F	OIL				
	SAE 5 110 SSU at 100°F 40 SSU at 210°F	SAE 10 150 SSU at 100°F 43 SSU at 210°F	SAE 20 275 SSU at 100°F 50 SSU at 210°F	SAE 30 500 SSU at 100°F 65 SSU at 210°F	SAE 40 750 SSU at 100°F 75 SSU at 210°F
100	1.14	1.22	1.35	1.58	1.77
150	1.01	1.05	1.11	1.21	1.31
200	.99	1.00	1.01	1.08	1.10
250	.95	.98	.99	1.00	1.00

Desired Reservoir Temperature

Return Line Cooling: Desired temperature is the oil temperature leaving the cooler. This will be the same temperature that will be found in the reservoir.

Off-Line Recirculation Cooling Loop: Desired temperature is the oil temperature entering the cooler. In this case, the oil temperature change must be determined so that the actual oil leaving temperature can be found. Calculate the oil temperature change (oil Δ T) with this formula:
 Oil Δ T = (BTU's/Hr.) / (GPM Oil Flow x 210).
 To calculate the oil leaving temperature from the cooler, use this formula:
 Oil Leaving Temp. = Oil Entering Temp – Oil Δ T.
 This formula may also be used in any application where the only temperature available is the entering oil temperature.

Oil Pressure Drop: Most systems can tolerate a pressure drop through the heat exchanger of 20 to 30 PSI. Excessive pressure drop should be avoided. Care should be taken to limit pressure drop to 5 PSI or less for case drain applications where high back pressure may damage the pump shaft seals.

Oil Temperature

Typical operating temperature ranges are:

Hydraulic Motor Oil	110° - 130°F
Hydrostatic Drive Oil	130° - 180°F
Bearing Lube Oil	120° - 160°F
Lube Oil Circuits	110° - 130°F